

## Salire® 100

Manual chain roller system

### Key Features :

- 4:1 ratio chain mechanism for easy operation on large blinds
- Built in auto stop mechanism for upper and lower limit setting
- Robust anti-deflection 47 mm diameter tube
- Aesthetic end caps
- Aesthetic aluminum fascia available as an option
- Face, top or wall fixing options
- Additional weightening by steel profile is possible (Only with exposed bottom bar)

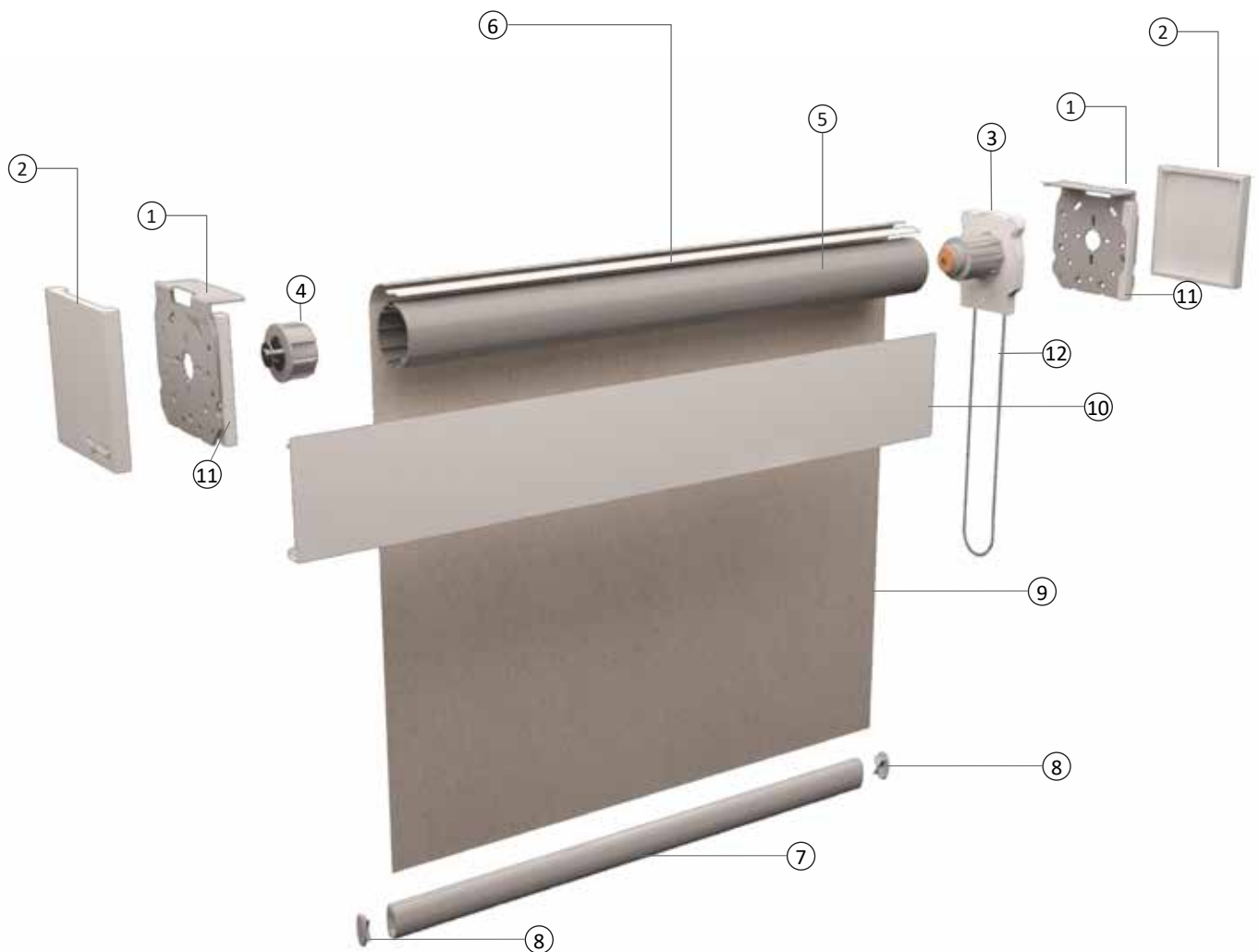

1. Mounting brackets  
2. Bracket end cap  
3. Operating clutch

4. End plug  
5. Tube  
6. Mounting spline

7. Hem bar  
8. End cap hem bar  
9. Fabric

10. Optional fascia  
11. Fascia support  
12. Ball chain