

Salire® 100-GW

Roller system with guide wire

Key Features :

- 4:1 ratio chain mechanism for easy operation on large blinds
- The guide wire will stabilize the roller blind
- Built in auto stop mechanism for upper and lower limit setting
- Robust anti-deflection duty 47 mm diameter tube
- Aesthetic end cap
- Aesthetic aluminum fascia available as an option
- Face, top or wall fixing options
- Additional weighting by steel profile is possible (Only with exposed bottom bar)

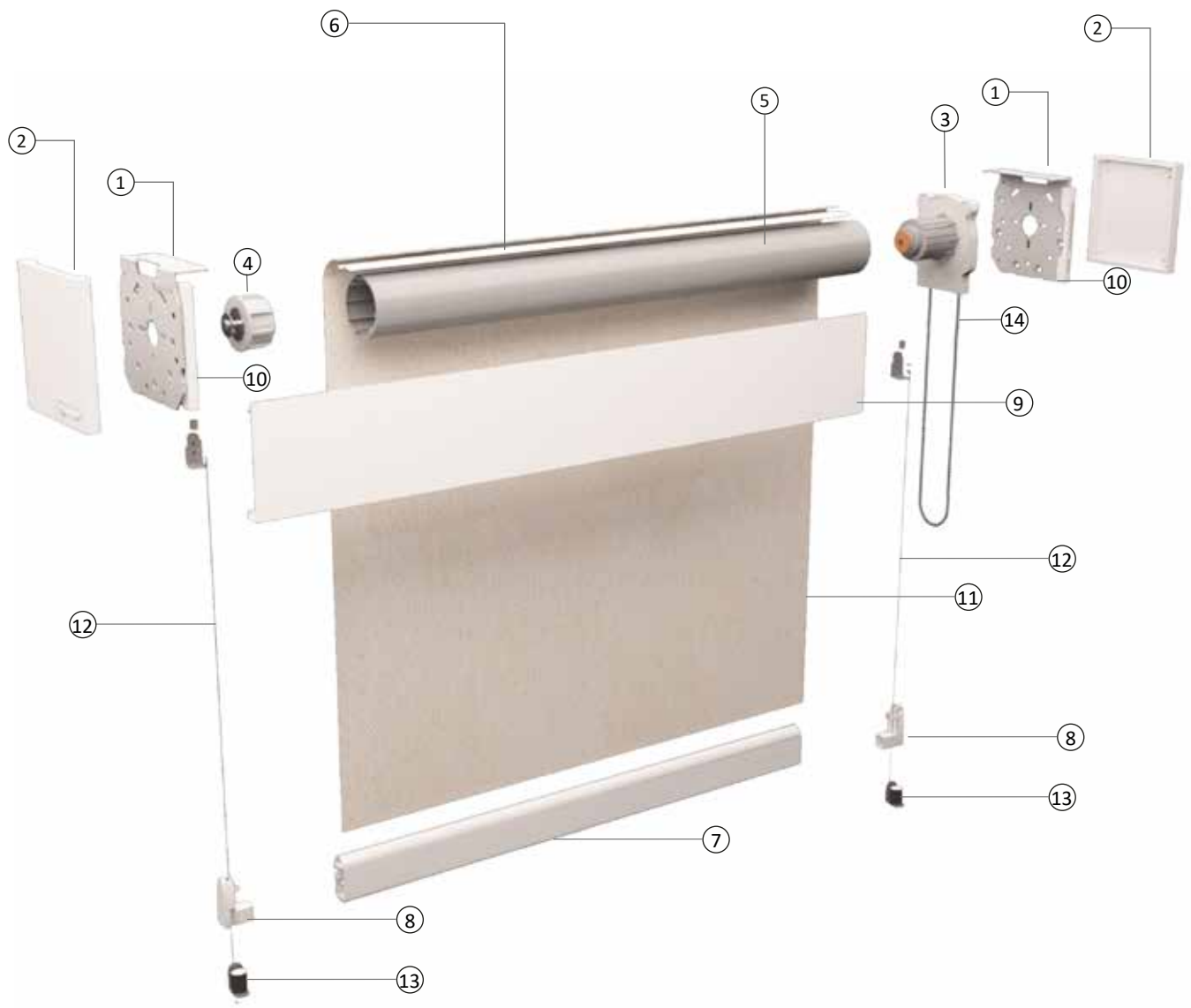

1. Mounting brackets
2. Bracket cover
3. Operating clutch
4. End plug

5. Tube
6. Mounting spline
7. Hem bar
8. End cap hem bar

9. Optional fascia
10. Fascia support
11. Fabric
12. Guide wire

13. Holder guide wire
14. Ball chain