

Salire® 100-MB

Multi band roller system

Key Features :

- 4:1 ratio chain mechanism for easy operation on large blinds
- Up to 9 m² multi band operation with a single mechanism (max fabrics weight 8 kg)
- Built in auto stop mechanism for upper and lower limit setting
- Robust anti-deflection 47 mm diameter tube
- Aesthetic end caps
- Aesthetic aluminum fascia available as an option
- Face, top or wall fixing options
- Additional weighting by steel profile is possible (Only with exposed bottom bar)

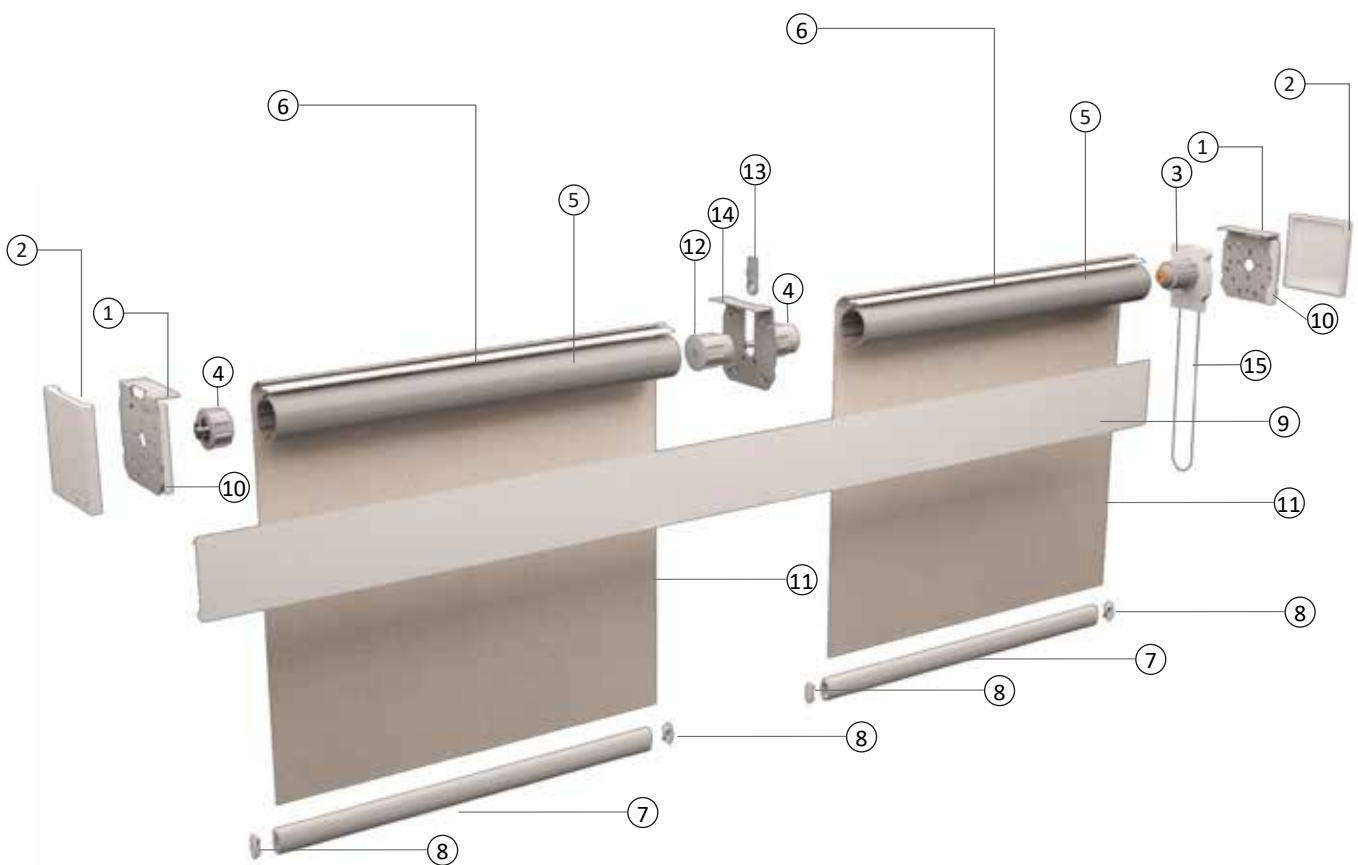

1. Mounting brackets
2. Bracket cover
3. Operating clutch
4. End plug

5. Tube
6. Mounting spline
7. Hem bar
8. End cap hem bar

9. Optional fascia
10. Fascia support
11. Fabric
12. Center end plug

13. Bearing plug
14. Center support bracket
15. Ball chain