

Salire® Double blind

Double blind roller system

Key Features :

- 4:1 ratio chain mechanism for easy operation on large blinds
- Double blind with single bracket system designed to install both sunscreen & blackout blinds
- Built in auto stop mechanism for upper and lower limit setting
- Robust anti-deflection 47 mm diameter tube
- Aesthetic end caps
- Aesthetic aluminum fascia available as an option
- Face, top or wall fixing options
- Additional weighting by steel profile is possible (Only with exposed bottom bar)

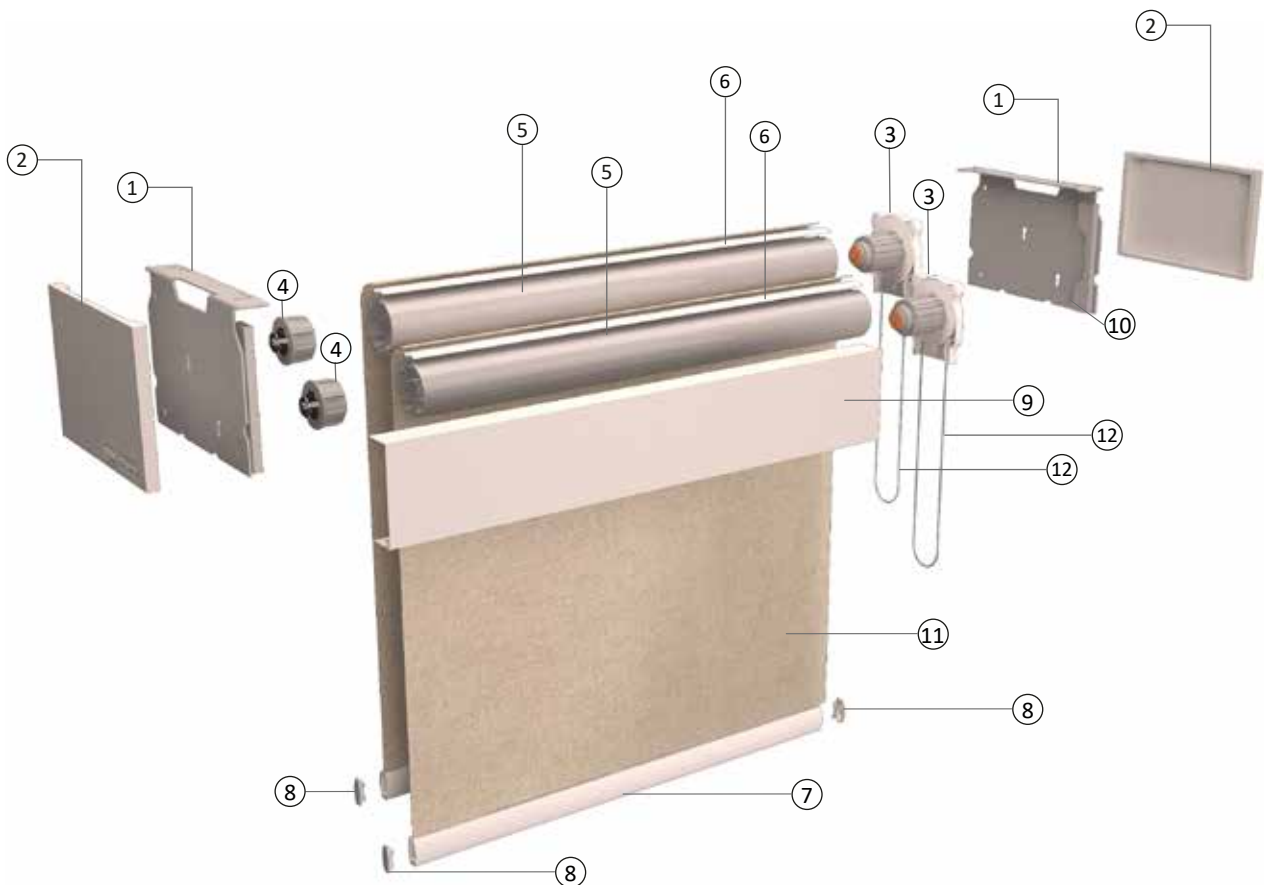

1. Mounting brackets

4. End plug

7. Hem bar

10. Fascia support

2. Bracket cover

5. Tube

8. End cap hem bar

11. Fabric

3. Operating clutch

6. Mounting spline

9. Optional fascia

12. Ball Chain