

Serena® 100-GW

Motorized roller system with guide wire

Key Features :

- Heavy duty VRS 230 VAC or SMI 230 VAC / 24 VDC motor installed within the roller blind tube
- The guide wire stabilizes the roller blind
- Built in auto stop mechanism for the upper and lower limit setting
- Robust anti deflection duty 47 mm diameter tube
- Aesthetic aluminum fascia available as option
- Face, top or wall fixing options

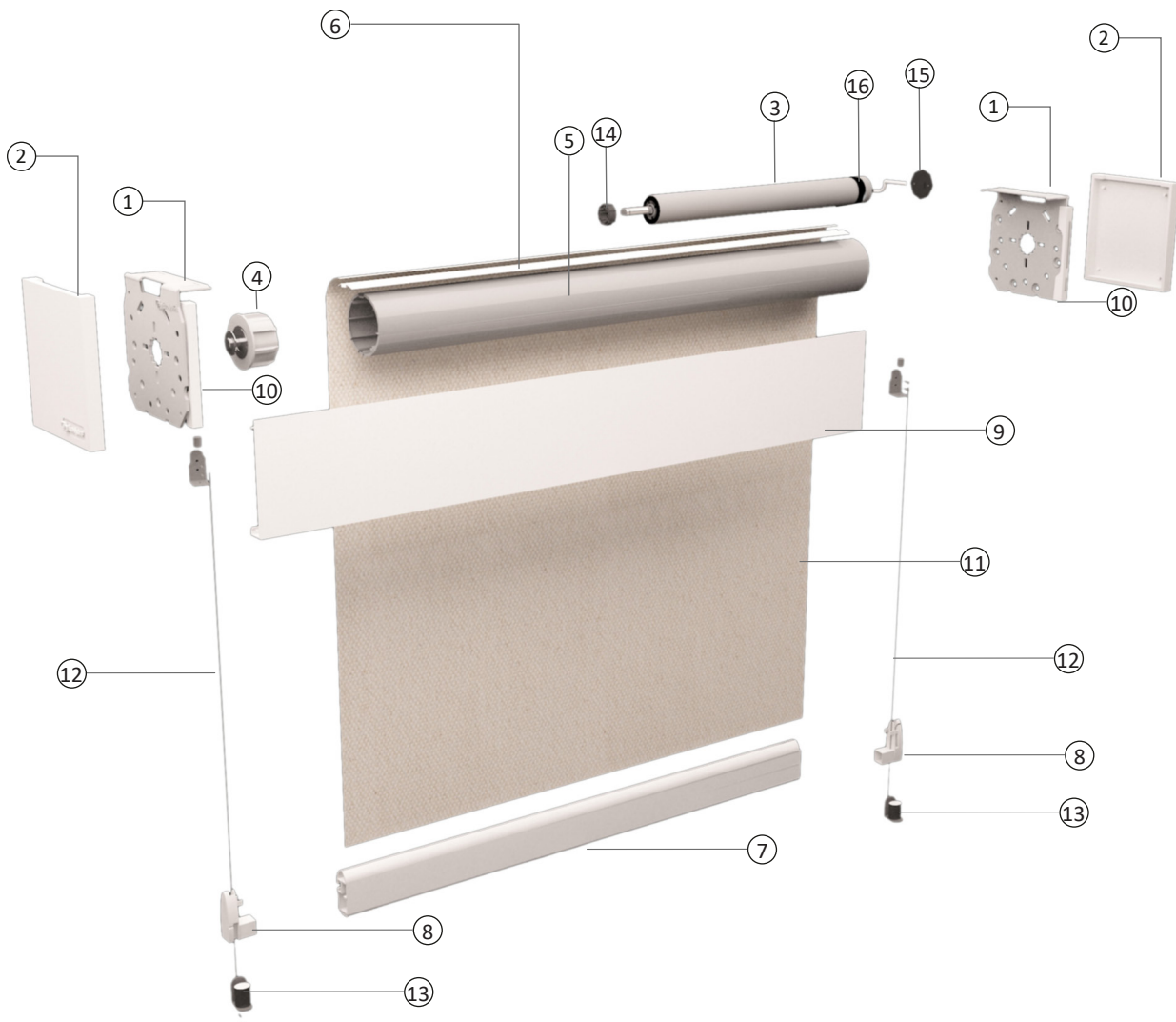

- | | | | |
|----------------------|--------------------|--------------------|-----------------------|
| 1. Mounting brackets | 5. Tube | 9. Optional fascia | 13. Holder guide wire |
| 2. Bracket cover | 6. Mounting spline | 10. Fascia support | 14. Shaft adapter |
| 3. Motor | 7. Hem bar | 11. Fabric | 15. Crown wheel |
| 4. End plug | 8. End cap hem bar | 12. Guide wire | 16. Motor plate |