

Serena[®] Wooden Blind

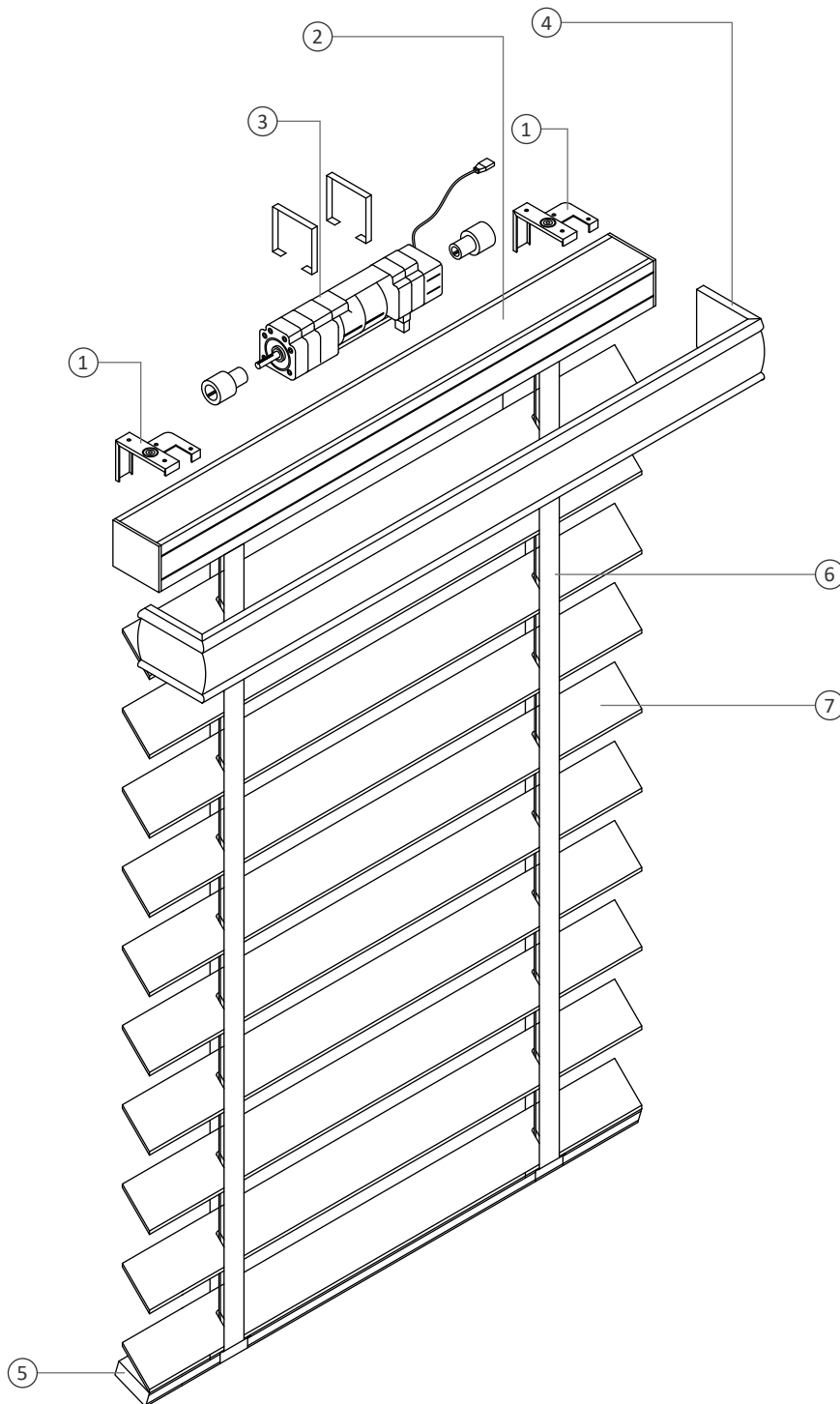

Note. The illustration above might change subject to design improvements

1. Bracket
2. Head profile
3. Motor

4. Valance
5. Bottom profile
6. Ladder braid

7. Wooden slat

**System specification Type Wooden venetian
Electrically operated wooden blind****Operation:**

Please select suitable motor as per project requirements from Euro Systems motor program.

Bracket:

The mounting brackets are designed to allow top, face or side fix installations. The bracket design enables quick and simple installation whilst minimizing the light gap between the blind and any recess. Universal mounting bracket 64x43x 19 mm.

Bracket mounting

Ceiling, wall or recess mounting.

Edge clearances:

Drive-end: 2 mm, idle-end: 2 mm

System configuration:

Head profile is made of extruded aluminum 58 x 51 mm. The wooden slats 51 x 3 mm are made of Basswood. The slats are attached to the profiles by ladder tapes or braids. For controlling the tilting and adjusting of blinds polyester cords (2.5 mm in diameter) are used.

Bottom profile is made of extruded aluminum 51x16mm

All system parts used are of high-quality, ageing resistant and UV resistant materials.

Maximum dimensions:

Max 3 x 3 m

Options:**Valance**

To cover the head profile and system configuration a valance made of aluminum 72x64x9mm can be installed in front of the head profile.

Colour coordination

The slats, valance or ladder tapes can be colour coordinated in matching or different colours.

Manufacturer:

Euro Systems UK Ltd.
Unit 11 Chancel Industrial park
Newhall Street, Willenhall
WV13 1NX, Unit, UNITED KINGDOM
E-mail: info@eurosystems.co.uk
Tel: +44 190 260 7111

Manufacturer:

(Middle East)
Euro Systems LLC
Meydan Road, Al Quoz 1, K.M.L Business Centre,
2nd Floor, Suite No: 227 Dubai, UAE
E-mail: info@eurosystems.com
Tel: +971 4 380 7744